

# MINERVA® Marine

## M600Ex Intrinsically Safe Fire Detection Range

### Features:

- Intelligent Universal Smoke/Heat/CO detector
- Low profile, discreet and unobtrusive
- Superior performance and reliability
- Designed for fast, easy installation
- Optional locking kit
- Integral and remote alarm LED
- Approved by all major classification societies for use on vessels



### M600Ex Fire Detection Range

Our sophisticated new Ex system for use in hazardous atmospheres introduces to the market a range of conventional I.S. fire detectors. In addition to the rugged, unobtrusive size and styled shape of the new range, a number of new design features have been incorporated including single visit to the deckhead installation and a service and maintenance detector park position.

## General

Included within the range is the High Performance Optical Smoke (HPO) detector and a combined Carbon Monoxide and Heat Detector.

The complete range has been designed to meet the requirements of EN (European Standards) for fire detectors and marine standards.

The detectors also carry the new CE mark.

## M600Ex Series Conventional Detectors

The M600Ex Series provides the detector part of an automatic fire detection system. The M600Ex Series Conventional or two state detector is one that provides two output states to the controller, either 'normal' or a 'fire alarm' condition.

The detectors along with callpoints are grouped into zones, with each zone being connected to the control panel by a two wire circuit. Each zone having a separate zone indicator at the control panel. Safety barriers are used to maintain the intrinsically safe status of the circuit under all conditions.

## Applications

As each type of fire detector responds to a particular 'fire product' the relative speed of response of the detector is therefore dependent upon the type of fire being detected. The range of M600Ex detectors have been designed to provide the earliest possible warning of a fire condition, with a minimum possibility of false/unwanted alarms.

As smoke is normally present at an early stage in most fires, smoke type detectors (high performance optical) are therefore considered the most useful. When considering the type of smoke detector for the application, the probable type of fuel for the fire should be considered. For general fire detection, where there is an equal possibility of either a 'fast' or 'slow' fire developing the intelligent high performance optical detector provides an excellent detection response.

In situations where the installation of smoke detectors would cause an unacceptable level of false alarms heat detectors may be installed. The M600Ex series provides a selection of heat detectors from Rate of Rise to fixed temperature.

Because of the wide variety of applications that fire detectors are expected to cover, it is recommended that you discuss your application with your local Fire and Security office.

## Fire Test Response

<b>Test Fire</b>	<b>Heat Developed</b>	<b>Smoke</b>	<b>Aerosol</b>	<b>Visible Portion</b>	<b>High Performance Optical</b>
TF1 Open Cellulosic fire (wood)	STRONG	YES	INVISIBLE	DARK	C
TF2 Smouldering Pyrolysis fire (wood)	NEGLIGIBLE	YES	VISIBLE	LIGHT	B
TF3 Glowing Smouldering fire (cotton)	NEGLIGIBLE	YES	INVISIBLE	LIGHT	B
TF4 Open Plastics fire (polyurethane)	STRONG	YES	INVISIBLE	VERY DARK	B
TF5 Liquid fire (n-heptane)	STRONG	YES	INVISIBLE	VERY DARK	B
TF6 Liquid fire (methylated spirits)	STRONG	NO	NONE	NONE	N

## High Performance Optical Smoke Detector MR601Ex



These detectors react to the whole range of fire products from slow smouldering fires, producing visible particles to open flaming fires producing large numbers of very hot smaller sized aerosols. It combines optical and heat detector technology to detect clear burning fire products which hitherto could only be easily detected by ion-chamber detectors.

For normal ambient conditions, the high performance optical detector behaves as a normal optical detector. Only when a rapid rise in temperature is detected does the sensitivity of the detector increase and the presence of smoke will confirm a fire condition which will be transmitted as an alarm level. Used in paint stores, battery rooms, pump rooms and Zone 1 Ro-Ro deck.

## Heat Detector MD601Ex and MD611Ex



These detectors use two networked thermistors in a bridge configuration to provide a fast response, that depends both on absolute temperature and rate of rise of temperature.

The rate of rise/fixed temperature heat detectors can be used in areas where smoke sensors are unsuitable due to environmental conditions (smoke, dust etc.). Such areas include galleys, pantries, laundry rooms etc.

## Enhanced Carbon Monoxide Fire and Heat Detector MDU601Ex



The MDU601Ex detector combines the features of both the MU601Ex detector and the MD601Ex detector to provide a combined CO and Rate-of-Rise Heat detector where the sensitivity of the CO detector is enhanced in response to a fast rate of change of temperature.

## Technical Specifications

### Mechanical

Detector Material	FR110 "Bayblend" Fire resistant
Dimensions	See diagram below
Weight	0.2Kg detector and base (approx)
Colour	White

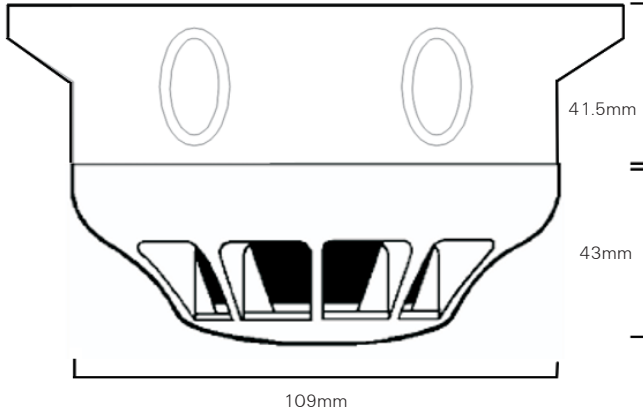

### Environmental

Operating Temp. Range	-10°C to +55°C
Storage Temp.	-20°C to +55°C
Relative Humidity	90% non condensing

### Electrical

Supply Voltage	16 to 28Vd.c.
Quiescent Current	100µA typical
Alarm Current	48mA typical
Reset Time	0.5 - 5 seconds
Wiring Connections	SEM Terminal 2 x 1.5mm <sup>2</sup>

### Electromagnetic Compatibility

ESD	to EN50081-1
Radiated	to EN50130-4
Fast Transient	to EN50130-4
Slow High Energy	to EN50130-4

### Approvals

These detectors have the following approvals:

ABS	American Bureau of Shipping
BV	Bureau Veritas
DNV	Det Norske Veritas
KRS	Korean Register of Shipping
LRS	Lloyds Register of Shipping

