



Description : Gas Detection Control Unit for detection and measurement of flammable and / or toxic gases as well as oxygen. Graphic display. 2 alarm levels. 2 alarm, horn and fault relays. Analogue output 4-20 mA.

Features

- Number of Transmitters : 1
- Signal Processing : Microcontroller with A/D-Converter
- Alarm / Fault / Indication: :
 - illuminated 4-lined display for indication of measured, messages and alarms, bar graph indication of concentration
 - 1 green operation LED
 - 2 red alarm LEDs (alarm levels 1 and 2)
 - 1 yellow LED for indication of device and transmitter fault
- Alarm Levels : 2 freely adjustable alarm levels per channel, latching configurable
- Relays : 4 change-over contacts 230 V / 200 mA for alarm 1 and 2, fault, horn
- Additional Functions :
 - completely configurable at the control unit via 4 keys
 - RS 232/RS 485 interface for communication with external Periphery (PC or PLT-System)
 - Alarm locking in maintenance mode
 - Horn alarm separately reset able
 - Analogue output 4-20 mA
- Operation Temperature : -10 °C to +40 °C

Mechanical Features

- Dimensions : 194 mm x 160 mm x 110 mm (Height x Width x Depth)
- Installation : Snap-In installation on Standard DIN-Rails (acc. to DIN EN 50022/50035)
- Material : Housing ABS
- Enclosure Rating : IP 54
- Storage Temperature : -25 °C to +60 °C

Electrical Features

- Power Supply : 24 V DC
- Power Consumption : Max. 0.8 A / 20 W
- Cable Gland :
 - 1 x M20 x 1.5 (diameter of cable 7-13 mm)
 - 5 x M16 x 1.5 (diameter of cable 5-10 mm)

Conformity

- EC-Directives : CE II (3)G
 94/9/EC (ATEX), 89/336/EEC (EMC), 73/23/EEC (LVD)
- Measuring Function : Designed according to
 - EN 61779-1 to EN 61779-4
 - EN 45544-1 to EN 45544-3
 - EN 50104

**Gas Detection Control Unit ET-1DA
for DIN-Rail installation, 24 V DC**
Article-No.: 305005

Drawing

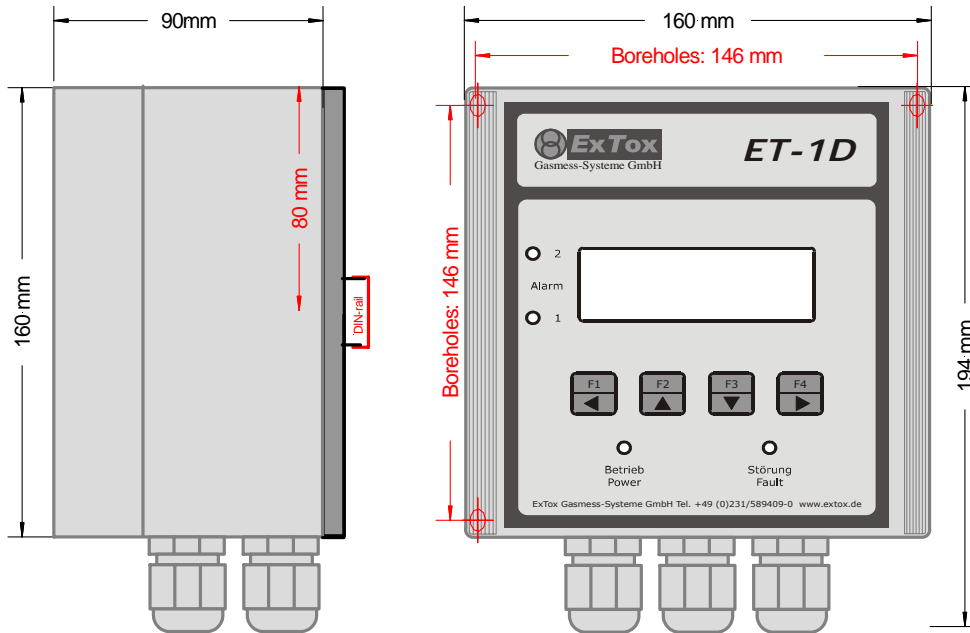

Installation

- : • Adapters are mounted at the back plate to snap-in the housing on the DIN-rails. The connection can easily be loosened by a screw-driver. Pull up the nozzle of the adapter.
- The housing can be opened for installation and maintenance purposes. The cover can now be opened and tucked up. Provide free space above the housing.

Connection Scheme

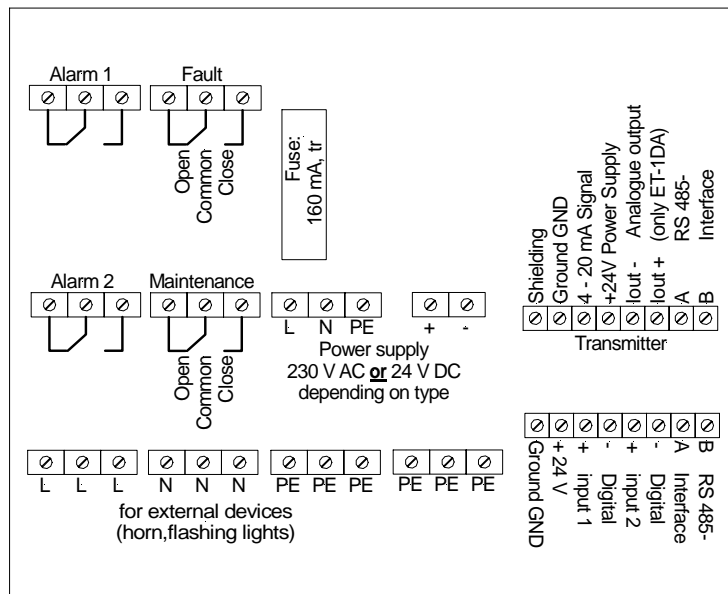

This Data Sheet is at the same time a type specific supplement to the Instruction Manual *ExTox Gas Detection Control Unit Series ET-1D*.

(Subject to technical changes)