



(Photo shows wall mounted version)

Description : Gas Detection Control Unit for detection and measurement of flammable and / or toxic gases as well as oxygen. Graphic display. 2 alarm levels. 2 alarm, horn and fault relays.

Features

Number of Transmitters : 1
 Signal Processing : Microcontroller with A/D-Converter
 Alarm / Fault / Indication: :

- illuminated 4-lined display for indication of measured, messages and alarms, bar graph indication of concentration
- 1 green operation LED
- 2 red alarm LEDs (alarm levels 1 and 2)
- 1 yellow LED for indication of device and transmitter fault

 Alarm Levels : 2 freely adjustable alarm levels per channel, latching configurable
 Relays : 4 change-over contacts 230 V / 200 mA for alarm 1 and 2, fault, horn
 Additional Functions :

- completely configurable at the control unit via 4 keys
- RS 232/RS 485 interface for communication with external Periphery (PC or PLT-System)
- Alarm locking in maintenance mode
- Horn alarm separately reset able

 Operation Temperature : -10 °C to +40 °C

Mechanical Features

Dimensions : 196 mm x 296 mm x ca. 120 mm (Height x Width x Depth)
 Installation : Control panel installation
 Option: separate box with connections clamps for remote installation in a cabinet
 Material : Front lid: polystyrene with front seal
 Enclosure Rating : IP 54 (front lid)
 Storage Temperature : -25 °C to +60 °C

Electrical Features

Power Supply : 230 V AC
 Power Consumption : Max. 0.08 A / 18 W

Conformity

EC-Directives : CE II (3)G
 94/9/EC (ATEX), 89/336/EEC (EMC), 73/23/EEC (LVD)
 Measuring Function : Designed according to

- EN 61779-1 to EN 61779-4
- EN 45544-1 to EN 45544-3
- EN 50104

Gas Detection Control Unit ET-1D
for Control Panel installation, 230 V AC
 Article-No.: 303002

Drawing

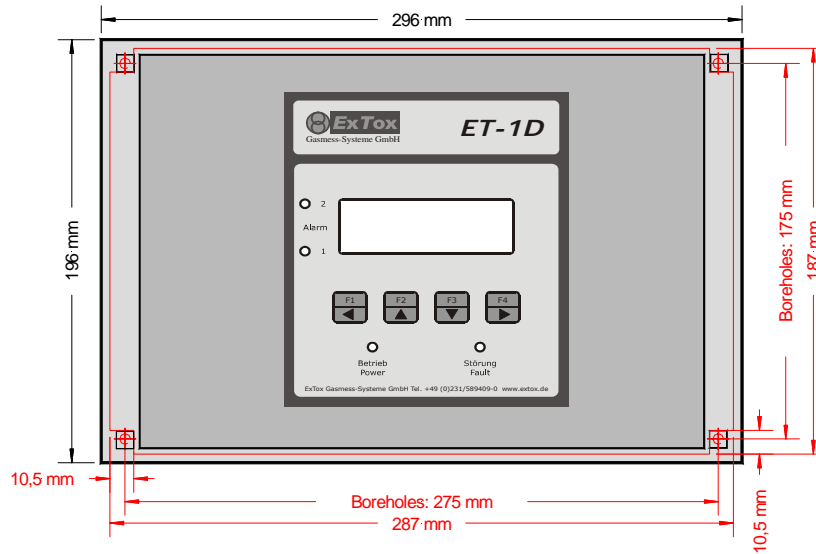

- Installation** :
- Cut out for the control panel and position of boreholes used for wall mounting are marked red in the drawing.
 - Maximum diameter of mounting screws: d= 3 mm

Connection Scheme

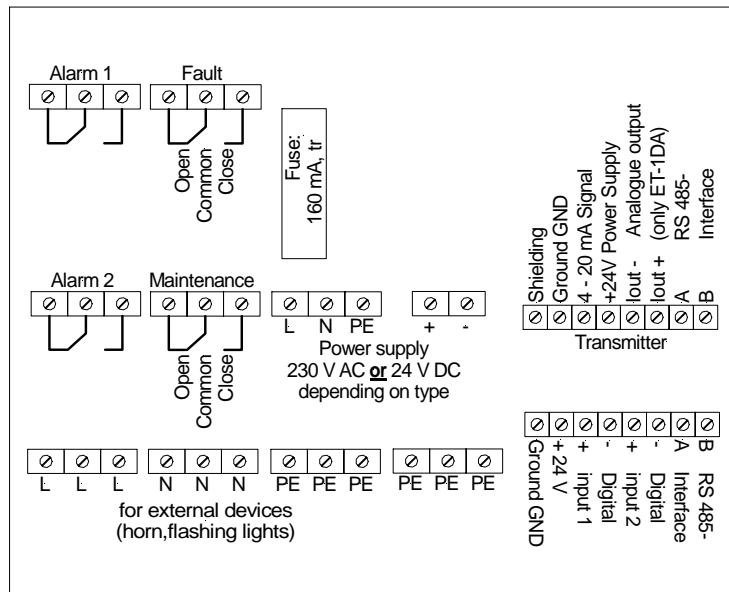

This Data Sheet is at the same time a type specific supplement to the Instruction Manual *ExTox Gas Detection Control Unit Series ET-1D*.

(Subject to technical changes)