



Description : Gas Detection Control Unit for detection and measurement of flammable and / or toxic gases as well as oxygen. Graphic display. 2 alarm levels. 2 alarm, horn and fault relays.

#### Features

Number of Transmitters : 1  
 Signal Processing : Microcontroller with A/D-Converter  
 Alarm / Fault / Indication: :
 

- illuminated 4-lined display for indication of measured, messages and alarms, bar graph indication of concentration
- 1 green operation LED
- 2 red alarm LEDs (alarm levels 1 and 2)
- 1 yellow LED for indication of device and transmitter fault

 Alarm Levels : 2 freely adjustable alarm levels per channel, latching configurable  
 Relays : 4 change-over contacts 230 V / 200 mA for alarm 1 and 2, fault, horn  
 Additional Functions :
 

- completely configurable at the control unit via 4 keys
- RS 232/RS 485 interface for communication with external Periphery (PC or PLT-System)
- Alarm locking in maintenance mode
- Horn alarm separately reset able

 Operation Temperature : -10 °C to +40 °C

#### Mechanical Features

Dimensions : 194 mm x 160 mm x 110 mm (Height x Width x Depth)  
 Installation : Snap-In installation on Standard DIN-Rails (acc. to DIN EN 50022/50035)  
 Material : Housing ABS  
 Enclosure Rating : IP 54  
 Storage Temperature : -25 °C to +60 °C

#### Electrical Features

Power Supply : 230 V AC  
 Power Consumption : Max. 0.08 A / 18 W  
 Cable Gland :
 

- 1 x M20 x 1.5 (diameter of cable 7-13 mm)
- 5 x M16 x 1.5 (diameter of cable 5-10 mm)

#### Conformity

EC-Directives : CE II (3)G  
 94/9/EC (ATEX), 89/336/EEC (EMC), 73/23/EEC (LVD)  
 Measuring Function : Designed according to
 

- EN 61779-1 to EN 61779-4
- EN 45544-1 to EN 45544-3
- EN 50104

**Gas Detection Control Unit ET-1D  
for DIN-Rail installation, 230 V AC**  
Article-No.: 303001

**Drawing**

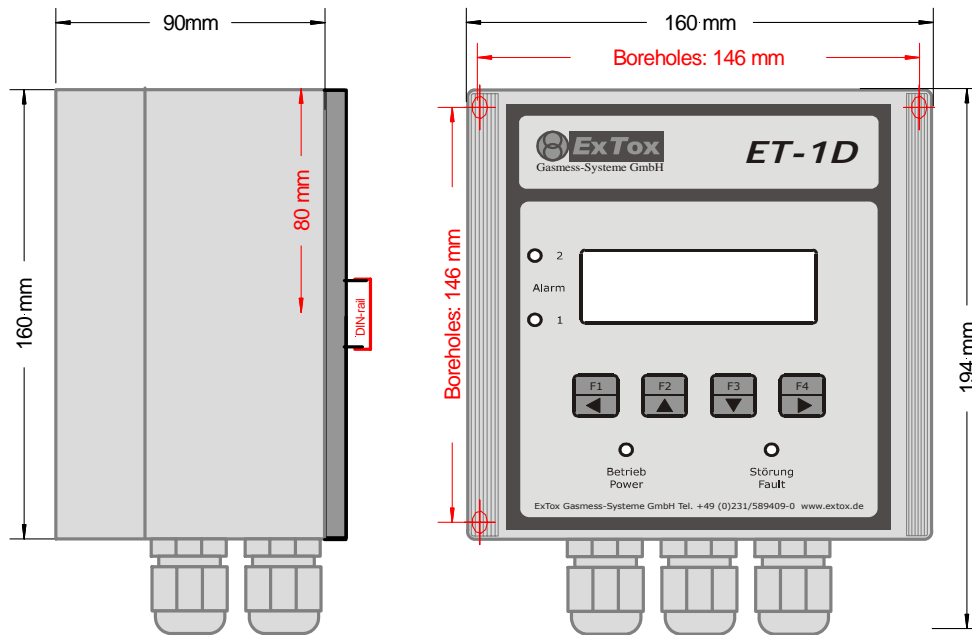

**Installation**

- Adapters are mounted at the back plate to snap-in the housing on the DIN-rails. The connection can easily be loosened by a screw-driver. Pull up the nozzle of the adapter.
- The housing can be opened for installation and maintenance purposes. The cover can now be opened and tucked up. Provide free space above the housing.

**Connection Scheme**

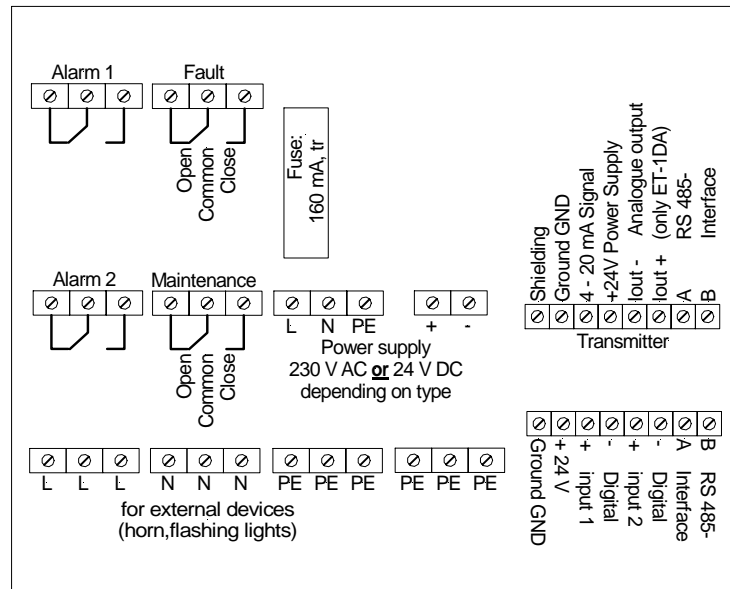

This Data Sheet is at the same time a type specific supplement to the Instruction Manual *ExTox Gas Detection Control Unit Series ET-1D*.

(Subject to technical changes)